

 **DATALOGIC**

# Magellan™ 1500i Omnidirectional Imaging Scanner



**Quick Reference Guide**

**Datalogic S.r.l.**

Via S. Vitalino, 13  
40012 Calderara di Reno — Italy  
Tel. +39 051 3147011  
Fax +39 051 3147205

©2018 Datalogic S.p.A. and/or its affiliates

An Unpublished Work — All rights reserved. No part of the contents of this documentation or the procedures described therein may be reproduced or transmitted in any form or by any means without prior written permission of Datalogic S.p.A. and/or its affiliates. Owners of Datalogic products are hereby granted a non-exclusive, revocable license to reproduce and transmit this documentation for the purchaser's own internal business purposes. Purchaser shall not remove or alter any proprietary notices, including copyright notices, contained in this documentation and shall ensure that all notices appear on any reproductions of the documentation. Should future revisions of this manual be published, you can acquire printed versions by contacting your Datalogic representative. Electronic versions may either be downloadable from the Datalogic website ([www.datalogic.com](http://www.datalogic.com)) or provided on appropriate media. If you visit our website and would like to make comments or suggestions about this or other Datalogic publications, please let us know via the "Contact Datalogic" page.

**Disclaimer**

Datalogic has taken reasonable measures to provide information in this manual that is complete and accurate, however, Datalogic reserves the right to change any specification at any time without prior notice.

Datalogic and the Datalogic logo are registered trademarks of Datalogic S.p.A. in many countries, including the U.S.A. and the E.U.

Magellan is a trademark of Datalogic S.p.A. or of Datalogic and/or its affiliates, registered in many countries, including the U.S. and the E.U.

**Patents**

See [www.patents.datalogic.com](http://www.patents.datalogic.com) for patent list.

**See the Regulatory Addendum included with your product for additional regulatory, safety and legal information.**



# Table of Contents

Quick Reference .....	1
Features .....	1
Installation .....	3
Optional Stand/Riser .....	3
Removing the Stand/Bottom Cover .....	4
Magnetic Base Mounting .....	4
How to Scan .....	5
Handheld Scanning Mode .....	5
Center Zone Qualification .....	6
Scanner Button .....	6
Scanner Button Functions .....	6
LED and Beeper Indicators .....	8
Programming .....	10
Service Port Mode .....	10
Using Barcodes .....	10
Interface Selection .....	11
Good Read Green Spot Duration .....	12
Cell Phone Mode .....	13

Cell Mode Frequency.....14

Troubleshooting.....15

    Error Codes.....16

Cleaning.....17

    Manufacturer Approved Cleaning Materials.....18

Warranty.....19



# Magellan™ 1500i

## Quick Reference

This guide is provided to help get your scanner up and running quickly and efficiently. For more details, including additional programming information, reference the Product Reference Guide (PRG), which is available from the Datalogic website.

## Features

Figure 1. Scanner Features - Front View

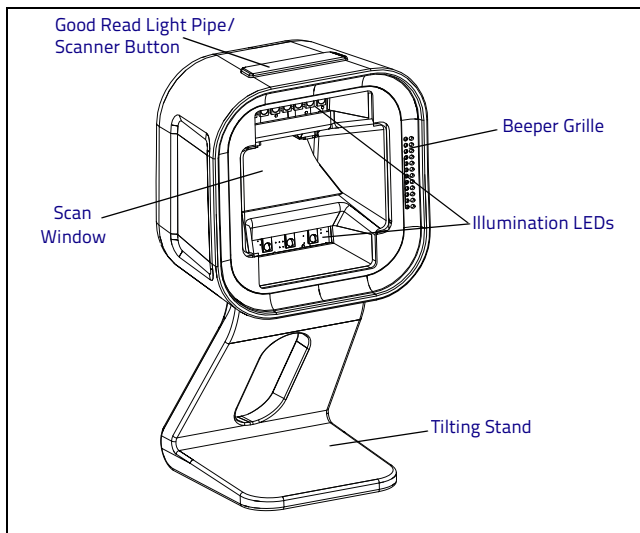

**Figure 2. Scanner Features - Bottom View**

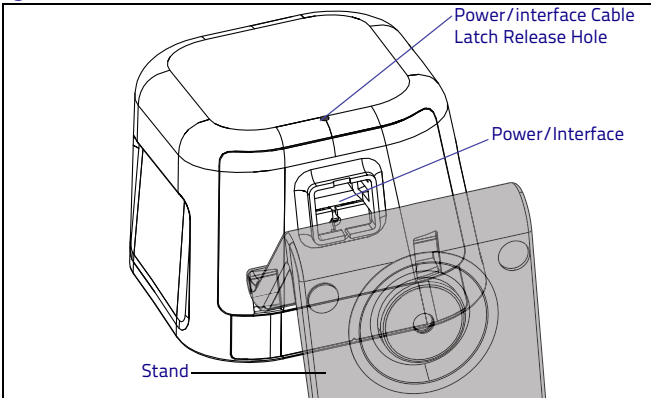

**Figure 3. Labeling**

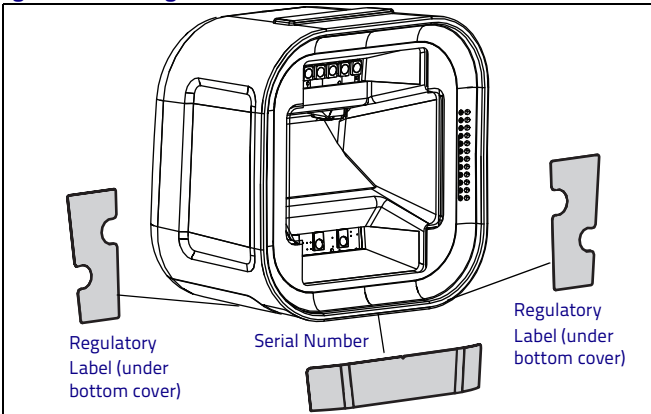

**NOTE**

Remove the stand/cover to view the Regulatory Labeling, as described on page 4. Labels are shown to illustrate their location only. Please view the labels on your product for actual details.

---

## Installation

Route the interface cable from the terminal or host. Plug the AC adapter (if one is used) into a wall outlet and the interface (I/F) cable, then route and attach the I/F cable to the scanner. Verify operation by presenting known-good bar codes to the scanner. The unit should beep<sup>1</sup> and/or flash its good read LED and send the bar code data to the host or terminal. If not, refer to the Troubleshooting section of this guide.

Scanner installation is complete.

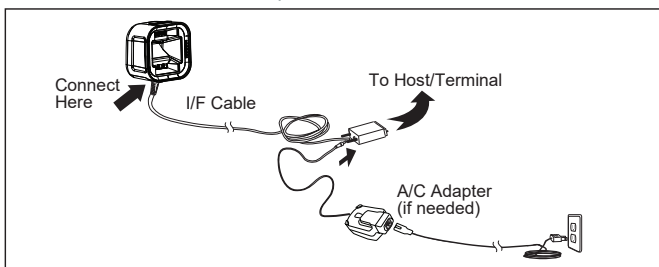

The Magellan 1500i uses intelligent illumination technology to optimize light levels for a variety of bar code scanner functions including automatic reading of bar codes from printed surfaces, mobile devices and image capture in variable contrast environments.

### Optional Stand/Riser

An optional stand / riser is available for the scanner. The stand and riser have anti-skid pads on the bottom and can rest on any desired horizontal surface or countertop. The scanner (along with the stand/riser) can be easily repositioned on the counter or lifted for portable use.

---

1. Beeper and LED behavior is selectable and may have been disabled by a previous user.

---

## Removing the Stand/Bottom Cover



### CAUTION

Do not attempt to remove the Stand without first unplugging the Cable as described. Doing so may result in damage to the scanner.

1. Unplug the Power Interface Cable by inserting a paper clip or similar object into the latch release hole as shown in [Figure 2 on page 2](#).
2. After removing the Interface Cable, pull the bottom of the Stand forward (in the direction of the Front Window) to detach it from the unit. It will snap free easily if oriented correctly.

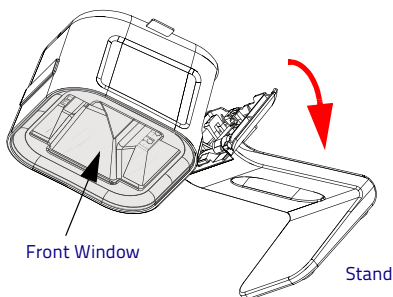

## Magnetic Base Mounting

The magnetic swivel base can be used to semi-permanently attach a scanner to a flat surface (vertical or horizontal), using the provided adhesive or screw. Both the stand and riser options mount onto the magnetic swivel base and are held magnetically in place. The scanner can easily be rotated to a desired orientation. The scanner (along with the riser or stand) can be detached for portable use by lifting the entire unit as shown in [Figure 4 on page 5](#).



---

## How to Scan

Bar codes can be presented to the scanner while it is resting on the counter or in the optional stand, or the scanner can be picked up for targeted scanning.

**Figure 4. Scanning Methods**

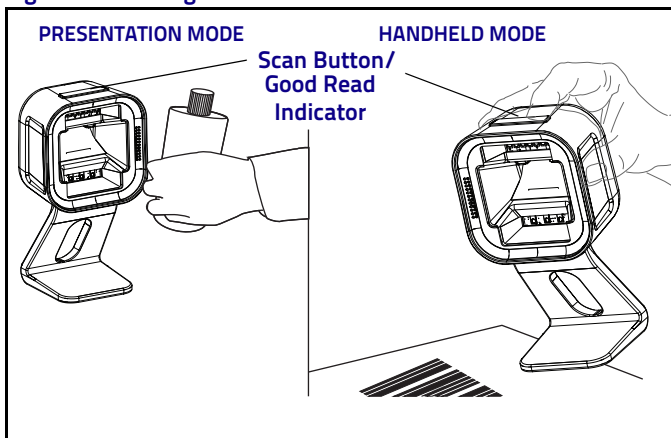

### Handheld Scanning Mode

To read a barcode using Handheld Scanning Mode:

1. Pick up the scanner- the aimer LED will illuminate automatically.
2. With the aimer over the barcode to be read, press and release the button.

Upon a successful read, the button will blink bright green and the GreenSpot™ will illuminate, highlighting the decoded barcode.

---

## Center Zone Qualification

The configurable Center Zone can be set to limit the scan area to allow Targeted Scanning of pick lists or other special items. Bar codes will read in any orientation. The scanner will return to full pattern Presentation Mode when set back down, after a configurable time has elapsed.

## Scanner Button

The Scanner Button performs multiple functions, depending on how long it is pressed:

### Scanner Button Functions



#### NOTE

The Scanner Button functions shown below are operational only when the Scanner is stationary. When in Hand/Portable mode, the button acts as a trigger to enable the reading of a barcode label.

PRESS DURATION	FUNCTION	COMMENT
Momentary (when scanner is asleep)	Wakes scanner from Sleep Mode	Alternatively, the scanner can be awakened by moving an object through the scan zone.
Momentary (when scanner is awake)	Increments volume	Press the button momentarily to increase speaker volume. When the loudest volume is reached, a repeated press of the button cycles volume back to the lowest setting, then volume increases on subsequent press(es). Five volume levels are available.

PRESS DURATION	FUNCTION	COMMENT
Hold, then release when the beeper sounds	Increments tone	Press the button for approximately 2 seconds, then release. Each time this is done, the beeper will sound at one of three tones. Stop when the desired tone (high, medium or low) is sounded.
4 Seconds	Scanner Diagnostics Mode <sup>a</sup>	This mode allows system support personnel to troubleshoot problems with the scanner and is used to determine if it can read bar codes. Press the button for 8 seconds or cycle power to exit Scanner Diagnostics Mode and reset the scanner.
10 Seconds	Resets Scanner <sup>b</sup>	Only system support personnel should perform a reset.

a. By standard default, this function is normally disabled to prevent accidental activation by users.

b. Users should not perform scanner resets except under the direction of trained systems support personnel.



#### NOTE

Volume changes made using the Scanner Button are lost when the scanner is powered down and are reset to the configured setting. If you wish to permanently change the volume, use the special programming labels in the Product Reference Guide.

---

## LED and Beeper Indicators

The scanner's beeper sounds and its green LED illuminates to indicate various functions or errors on the scanner. The tables that follow list these indications. An exception is that the scanner's functions are programmable, and may or may not be turned on. For example, some indications (such as the power-up beep) can be disabled using programming bar code labels.

LED INDICATION	INDICATION	COMMENT
Power-on indication	Bright green flash	Indicates the scanner has finished all its power-up tests and is now ready for operation.
Good Read Indication	Bright green flash	Indicates a bar code has been read and decoded.
Scanner Ready	Constant dim green	The scanner is ready for operation.
Sleep Mode	Green LED slowly and continuously changes from off to dim to off.	The scanner is in Sleep Mode. To wake the scanner up, move an object in front of its window or press the button atop the unit. This indication is optionally configurable, and may have been programmed to behave differently.
Host Disable	Constant green flash at 1 Hz (100mS on, 900mS off)	The scanner is disabled due to receiving a disable command from the POS terminal.
Diagnostics	Varies (see <a href="#">Error Codes on page 16</a> for more information)	The LED can provide diagnostic feedback if the scanner discovers a problem during SelfTest.
Prog. Mode	Constant green flash at 1 Hz (500 ms on, 500 ms off).	The scanner is in Programming Mode.

BEEPER INDICATION	INDICATION	COMMENT
Power On Beep	Single beep	The Power-On LED indication is a configurable feature which can be enabled or disabled. When enabled, this beep indicates the scanner has finished all its power-up tests and is now ready for operation.
Good Read Indication	Single beep	The good read beep indication is configurable. Options include: Enable/disable, frequency, duration and volume. See the Product Reference Guide (PRG) for more information.
Diagnostics	Varies (see <a href="#">Error Codes on page 16</a> for more information)	The Beeper can provide diagnostic feedback if the scanner discovers a problem during SelfTest.
Programming Mode Indications	Varies depending upon the feature(s) being configured.	The Beeper will sound as programming bar code labels are scanned, indicating progress during scanner configuration.

---

## Programming

On leaving the factory, units are generally programmed with the most common terminal and communications settings. If you need to change these settings, custom programming can be accomplished using one of several methods.

This manual offers programming barcodes for common functions. Additional programming barcodes are available in the PRG, or use software utilities such as Datalogic Scanalyzer or Datalogic Aladdin, all available on the Datalogic website.

### Service Port Mode

To program the Magellan 1500i using Scanalyzer or Aladdin, the unit must first be placed into Service Port mode, as follows:

1. Unplug the unit if needed.
2. While Holding down the Scan Button on the top of the unit, plug the scanner in.
3. The scanner will enter Service Port Mode, enabling it to be programmed via software utilities.

## Using Barcodes



### NOTE

**It is not necessary to place the scanner into Service Port Mode to program with barcode labels.**

After completing the physical connection between the scanner and its host, go to the Programming Bar Codes table on the following pages to locate the interface type for your scanner (such as RS-232, USB, etc.).

Scan a START/END bar code once to enter Programming Mode. After scanning the programming label for the desired interface, scan the START/END barcode a second time to accept your changes, exit Programming Mode and return the scanner to normal operation.

---

## Interface Selection



START / END

### PROGRAMMING BAR CODES



RS-232 Standard



RS-232 Wincor-Nixdorf



USB-OEM



USB Keyboard



USB COM Interface



### NOTE

Reference the Product Reference Guide (PRG) or configuration software (such as Datalogic Aladdin or ScanaLyzer) for additional options. All are available for download at no charge.

---

## Good Read Green Spot Duration

Successful reading can be signaled by a good read green spot. Use the bar codes that follow to specify the duration of the good read pointer beam after a good read.



START / END



Disabled



◆ Short (300 ms)



Medium (500 ms)



Long (800 ms)



---

## Cell Phone Mode

Enables/disables mobile phone barcode reading.

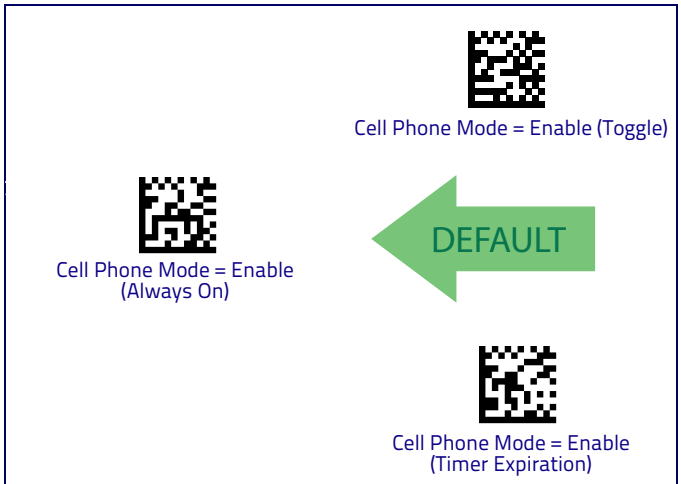

# Cell Mode Frequency

Specifies the frequency when reading cell phones. Cell phone mode must be enabled for this feature to be active.



### NOTE

Higher Settings will slow down read performance on printed barcodes.



START / END



Cell Mode Frequency = Very Low



Cell Mode Frequency = Low



Cell Mode Frequency = Medium



Cell Mode Frequency = Med High



Cell Mode Frequency = High

---

## Troubleshooting

If the scanner is not operating properly, the following checks should be performed:

PROBLEM	SOLUTION
Scanner does not power on	Exchange the power supply with a known good power supply and retest operation.
	If an RS-232 cable is used on a scanner configured for USB, powerup will not occur because the scanner will be waiting for enumeration from the host.
	As a workaround, hold the scanner's button down, then apply power. Release the button when the green light comes on. The scanner will power up with limited scanning, which will allow you to scan programming labels to reconfigure the scanner to the desired interface.
No communication with the host	Verify the interface cable is securely attached to the host and the scanner. Consult your technical support personnel or refer to your host system manual to verify the proper interface type, cable and connection port(s) for the scanner.
The scanner will not read bar codes at all, or reads poorly	Check that the bar codes are of sufficient quality to be recognized by the scanner. Wrinkled, smudged, or torn labels can cause the scanner to not read at all. Scan known-good labels of an active symbology <sup>a</sup> to check the scanner's read operation.
	Make sure the window is clean.

a. Reading of the various bar code symbologies can be independently enabled or disabled in the scanner.

If the scanner still does not function properly, consult the Product Reference Guide (PRG) or contact your local supplier or Datalogic Customer Support Services

---

## Error Codes

If an error is detected, the scanner will sound a long low tone (for three seconds) and flash its LED, indicating a failure. When this occurs, press the Scanner button to hear the error code. If it is configured to do so, the scanner will sound a series of beeps corresponding to the error code and/or flash its LED simultaneous to the beeps. The table below describes what these codes mean and what action should be taken for each.

NUMBER OF LED FLASHES/ BEEPS	ERROR	CORRECTIVE ACTION
1	Configuration	Contact Helpdesk for assistance
2	Host Interface	
6	Main PCB	
10	Button Error	
11	USB Device	
13	FPGA ID	

---

## Cleaning

Exterior surfaces and scan windows exposed to spills, smudges or debris accumulation require periodic cleaning to assure best performance during scanning. Use a clean, lint-free cloth or paper towel dampened with a nonabrasive, mild, water-based cleaner to wipe away stains, smudges, fingerprints, spills, etc. from the scan window and exterior surfaces.

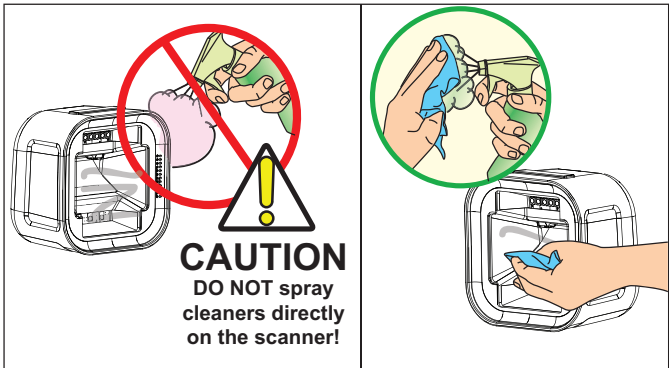

**CAUTION**

**DO NOT** use abrasive cleaning agents or abrasive pads to clean this product. Harsh chemicals, disinfectants, and cleansers can cause damage which will adversely affect scanning performance.

See the next page for a list of [Manufacturer Approved Cleaning Materials](#).

---

## Manufacturer Approved Cleaning Materials

Datalogic recommends the use of the following cleaners on its products.



### APPROVED CLEANERS

- Hydrogen Peroxide (not to exceed a 3% solution)
- Chlorine bleach (not to exceed a 0.25% solution)
- Mild detergent and water
- Isopropyl Alcohol (not to exceed a 70% solution)



**CAUTION**

**Use of above cleaners *in combination with each other* is not recommended and may constitute a health hazard. Follow all specified safety precautions when using any cleaning solution.**

Under no circumstances should abrasive cleansers, abrasive pads, caustic solutions or other harsh chemicals, including those listed below, be used on any part of the scanner as they can cause damage which will adversely affect scanning performance. Use of such materials, either alone or in combination with other cleaning agents, will void the manufacturer's warranty.



### !!DO NOT USE!!

- Ammonia solutions
- Acetone
- Benzene
- Ethanolamine
- Ethers
- Ketones
- Trichloroethylene
- Toluene
- Carboic acid
- Aromatic or chlorinated hydrocarbons
- Aqueous or alcoholic alkaline solutions

---

## Warranty

Datalogic warrants to Customer that this product will be free from defects in materials and workmanship for a period of 3 years from product shipment.

Datalogic warrants that the goods delivered under these General Terms for the Sale of Goods shall be free from defects in materials and workmanship under normal and proper use during the Warranty Period (as defined below). Datalogic's liability under this warranty is limited to furnishing the labor and parts necessary to remedy any defect covered by this warranty and restore the product to its normal operating condition. Repair or replacement of product during the warranty does not extend the original warranty term. Products are sold on the basis of specifications applicable at the time of manufacture and Datalogic has no obligation to modify or update products once sold. The warranty period shall extend from the date of shipment from Datalogic for the duration published by Datalogic for the product at the time of purchase ('Warranty Period').

If, during the Warranty Period, Datalogic determines that a product has defects in material or workmanship, Datalogic shall, at its sole option repair or replace the product without additional charge for parts and labor, or give a credit for the defective products duly returned to Datalogic. To perform repairs, Datalogic may use new or reconditioned parts, components, subassemblies or products that have been tested as meeting applicable specifications for equivalent new material and products. Buyer will allow Datalogic to scrap all parts removed from the repaired product. Datalogic warrants repaired hardware devices only, against defects in workmanship and materials on the repaired assembly for a 90 day period starting from the date of shipment of the repaired product from Datalogic or until the expiration of the original Warranty Period, whichever is longer. Datalogic does not guarantee, and it is not responsible for, the maintenance of, damage to, or loss of configurations, data, and applications on the repaired units and at its sole discretion can return the units in the 'factory default' configuration or with any software or firmware update available at the time of the repair (may be newer than the firmware or software installed during the manufacture of the product). Buyer accepts responsibility to maintain a backup copy of its software and data.

### Warranty Exclusions

The Datalogic Warranty shall not apply to:

- (i) any product which has been damaged, modified, altered, repaired or upgraded by other than Datalogic service personnel or its authorized representatives;
- (ii) defects or damages caused by any third parties' tort committed against the Buyer.
- (iii) any claimed defect, failure or damage which Datalogic determines was caused by faulty operations, improper use, abuse, misuse, wear and tear, negligence, improper storage or use of parts or accessories not approved or supplied by Datalogic;
- (iv) any claimed defect or damage caused by the use of product with any other instrument, equipment or apparatus;
- (v) any claimed defect or damage caused by the failure to provide proper maintenance, including but not limited to cleaning the upper window in accordance with product manual or the replacement of upper window/cartridge due to scratching, stain or other degradation;

- 
- (vi) any defect or damage caused by natural or man-made disaster such as but not limited to fire, water damage, floods, other natural disasters, vandalism or abusive events that would cause internal and external component damage or destruction of the whole unit, consumable items;
  - (vii) any damage or malfunctioning caused by non-restoring action as for example firmware or software upgrades, software or hardware reconfigurations etc.;
  - (viii) any consumable or equivalent (e.g. cables, power supply, batteries, etc.).

Consumable items, such as batteries and cables, carry a 90 day warranty from time of purchase for DOA (dead on arrival) defects alone.

Datalogic specifically excludes all express warranties and makes no implied warranty that the products sold under this agreement are merchantable or are fit for any particular purpose, except such warranties expressly identified as warranties as are set forth in Datalogic's current operating manual, catalog, or written guarantee covering such product.

No affirmation of fact or promise made by Datalogic, whether in this contract or communicated otherwise, shall constitute a warranty that the goods will conform to the affirmation or promise.

## Warranty Claim Process

In order to obtain service under this Warranty, Buyer must notify Datalogic (which notice shall be in writing sent by registered courier or mail) of the claimed defect before the expiration of the Warranty period and obtain from Datalogic a return authorization number for return of the product to designated Datalogic service center. Buyer shall offer Datalogic the opportunity to investigate the claim and to inspect the allegedly defective products. Failure to offer Datalogic such opportunity shall constitute acceptance by Buyer and waiver of all claims for defects. The products must always be returned within ten (10) days from the date of authorization issued by Datalogic. If Datalogic determines Buyer's claim is valid, Datalogic will repair or replace product without additional charge for parts and labor. Buyer shall be responsible for packaging and shipping the product to the designated Datalogic service center, with shipping charges prepaid. Datalogic shall pay for the return of the product to Buyer if the shipment is to a location within the country in which the Datalogic service center is located. Buyer shall be responsible for paying all shipping charges, duties, taxes, and any other charges for products returned to any other locations.

DATALOGIC'S WARRANTY, AS DESCRIBED HEREIN, IS IN LIEU OF ALL OTHER WARRANTIES, EXPRESS OR IMPLIED, ORAL OR WRITTEN, STATUTORY OR OTHERWISE, INCLUDING, WITHOUT LIMITATION, ANY IMPLIED WARRANTIES OF MERCHANTABILITY, FITNESS FOR A PARTICULAR PURPOSE, OR NONINFRINGEMENT. DATALOGIC SHALL NOT BE LIABLE FOR ANY DAMAGES SUSTAINED BY BUYER ARISING FROM DELAYS IN THE REPLACEMENT OR REPAIR OF PRODUCTS UNDER THE ABOVE. THE REMEDY SET FORTH IN THIS WARRANTY STATEMENT IS THE BUYER'S SOLE AND EXCLUSIVE REMEDY FOR WARRANTY CLAIMS. UNDER NO CIRCUMSTANCES WILL DATALOGIC BE LIABLE TO BUYER OR ANY THIRD PARTY FOR ANY LOST PROFITS, OR ANY INCIDENTAL, CONSEQUENTIAL INDIRECT, SPECIAL OR CONTINGENT DAMAGES REGARDLESS OF WHETHER DATALOGIC HAD ADVANCE NOTICE OF THE POSSIBILITY OF SUCH DAMAGES. DATALOGIC'S LIABILITY FOR DAMAGES ON ACCOUNT OF A CLAIMED DEFECT IN ANY PRODUCT DELIVERED BY DATALOGIC SHALL IN NO EVENT EXCEED THE PURCHASE PRICE OF THE PRODUCT ON WHICH THE CLAIM IS BASED. DATALOGIC SHALL NOT BE LIABLE FOR DAMAGES RELATING TO ANY INSTRUMENT, EQUIPMENT, OR APPARATUS WITH WHICH THE PRODUCT SOLD UNDER THIS AGREEMENT IS USED.



---

## **Out of Warranty Services**

For products no longer covered by warranty services, Datalogic may offer billable repair services on products, provided such products are serviceable. Buyer acknowledges and accepts that for some older products the repair may exceed the costs of manufacturing a new product and Datalogic may decline to perform repair services. Upon Buyer's request for out of warranty services, Datalogic will evaluate the request of repair and shall provide, to the extent applicable and feasible according to the above, a cost-estimate for repairs, which will be on a time and materials basis.

## **Remedies**

If Buyer fails, with or without cause, to furnish Datalogic with specifications and/or instructions for, or refuses to accept deliveries of, any of the products sold under this contract, or is otherwise in default under or in repudiation of this contract or any other contract with Datalogic or fails to pay when due any invoice under this contract, then in addition to any and all remedies allowed by law, Datalogic without notice may (1) bill and declare due and payable all undelivered products under this or any other contract between Datalogic and the Buyer; and/or (2) defer shipment under this or any other contract between the Buyer and Datalogic until such default, breach, or repudiation is removed; and/or (3) may cancel any undelivered portion of this and/or any other contract in whole or in part (with Buyer remaining liable for damages).

## **Risk of Loss**

Buyer shall bear risk of loss or damage for product in transit to Datalogic. Datalogic shall assume risk of loss or damage for product in Datalogic's possession. In the absence of specific written instructions for the return of product to Buyer, Datalogic will select the carrier, but Datalogic shall not thereby assume any liability in connection with the return shipment.

---

# NOTES





©2018 Datalogic S.p.A. and/or its affiliates ▪ All rights reserved ▪ Without limiting the rights under copyright, no part of this documentation may be reproduced, stored in or introduced into a retrieval system, or transmitted in any form or by any means, or for any purpose, without the express written permission of Datalogic S.p.A. and/or its affiliates  
▪ Datalogic and the Datalogic logo are registered trademarks of Datalogic S.p.A. in many countries, including the U.S. and the E.U.



[www.datalogic.com](http://www.datalogic.com)

**Datalogic S.r.l.**

Via S. Vitalino, 13 | 40012 Lippo di Calderara di Reno | Bologna - Italy  
Tel. +39 051 3147011 | Fax +39 051 3147205

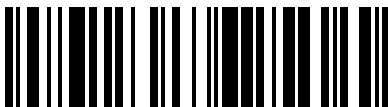

820173414

(Rev. A)

Dec 2018